



## DESIGNERS TORD BOONTJE

Tord Boontje werd in 1968 geboren in het Nederlandse Enschede. Hij studeerde eerst industriële vormgeving aan de Design Academy in Eindhoven (1986 – 1991), gevolgd door een Master-opleiding aan de Royal College of Art in Londen (1992 - 1994). Studio Tord Boontje is opgericht in 1996. Tord Boontje woonde en werkte van 1995 tot 2005 in Londen, waarna hij zijn huis en studio inruilde voor een woon- en werkplek in Bourg-Argental, Frankrijk. In 2009 kreeg hij een aanstelling als Professor en Head of Design Products aan de Royal College of Art en sindsdien werkt hij vanuit zijn ontwerpstudio in Londen.

De uitdaging en kans waar de Studio lang naar op zoek is geweest, is een delicate band tussen design en emotie die even toegankelijk als verleidelijk is. Het werk van de Studio is gebaseerd op de overtuiging dat modernisme niet per definitie minimalisme hoeft te betekenen, dat eigentijdsheid niet in strijd hoeft te zijn met traditie en dat technologie geen afstand doet van mensen en van gevoel. In de ontwerpen van de Studio worden harde elementen vaak vervaagd door zachte elementen, waarbij inspiratie wordt gezocht in de natuur en gebruik wordt gemaakt van vele verschillende vormen en lagen om de verbeelding te prikkelen van en emoties op te roepen bij aanschouwers. Deze verwijzingen naar de natuur en naar emotie weerspiegelen echter alleen het eindresultaat en geven niet het ontwerpproces zelf weer. Hoewel het gebruik van technologieën en de eigenschappen van materialen nooit op de voorgrond treden (en altijd subtiel zijn verweven met het uiteindelijke product), wordt toch bewust benadrukt dat de Studio werkt met de laatste productie- en materiaaltechnologieën bij het verwezenlijken van haar visie.

Tord Boontje ontwierp producten voor o.a. Moroso, Philips, Artecnic, Kvadrat en Hewlett-Packard. Twee ontwerpen van hem zijn opgenomen in de collectie van MoMa (The Museum of Modern Art) in New York: Transglass light (1997) en Garland light (2002). Voor FORMANI® ontwierp hij de serie deurbeslag 'FOLD'; een revolutionair ontwerp en bovendien een technisch hoogstandje.

---

Tord Boontje was born in Enschede, Netherlands in 1968. He first studied industrial design at the Design Academy in Eindhoven (1986 – 1991), and followed this with a Masters from the Royal College of Art in London (1992 - 1994). Studio Tord Boontje was founded in 1996. Tord Boontje lived and worked in London from 1995 to 2005, when he moved his home and studio to Bourg-Argental, France. In 2009 he took up his appointment as Professor and Head of Design Products at the Royal College of Art and continues work at his London-based design studio.

The challenge and opportunity the Studio has long sought is a delicate marriage of design with emotion that is as broadly accessible as it is enticing. The Studio's work draws from a belief that modernism does not mean minimalism, that contemporary does not forsake tradition, and that technology does not abandon people and senses. The Studio's designs often temper edges with softness, take inspiration from nature, and employ a décor of forms and layers to engage and entice an observer's imagination and emotions. But these references to nature and emotion reflect only an outcome, not the process of design itself. Although the use of technologies and material properties is never celebrated (and is always subsumed within the final product), there is nonetheless a conscious insistence that the Studio's work employ the latest production and material technologies in pursuit of its vision.

Tord Boontje has previously designed products for clients including Moroso, Philips, Artecnic, Kvadrat and Hewlett-Packard. Two of his designs are part of the collection of MoMa (The Museum of Modern Art) in New York: Transglass light (1997) and Garland light (2002). For FORMANI® he designed the 'FOLD' series of door fittings for Formani: a revolutionary design for lever handles and also an impressive technical feat.

FOLD by  
TORD BOONTJE



## FOLD by TORD BOONTJE

---

FOTOSHOOT GENK, BELGIË   ON LOCATION GENK, BELGIUM	114
DEURBESLAG   DOOR FITTINGS	132
deurkrukken   lever handles	132
accessoires deurkrukken   lever handle accessories	132
RAAMBESLAG   WINDOW FITTINGS	133
draaikiepbeslag   tilt and turn window handles	133
krukespagnoleetten   espagnolette bolts	133
VOORDEURBESLAG   FRONT DOOR FITTINGS	134
voordeurknoppen   front door knobs	134
grepen   pull handles	134
veiligheidscilinderrozetten   security escutcheons	134
beldrukkers   bell pushes	134
ACCESSOIRES   ACCESSORIES	135
meubelgrepen   cabinet handles	135
meubelknoppen   cabinet knobs	135
hefschuifdeurbeslag   sliding door handles	135



BELGIUM  
GENK

LOCATION: GENK, BELGIUM | OBJECT: JEPUN TRADITIONAL SPA | PHOTOGRAPHY: TYCHO MERIJN ROEST, THE NETHERLANDS













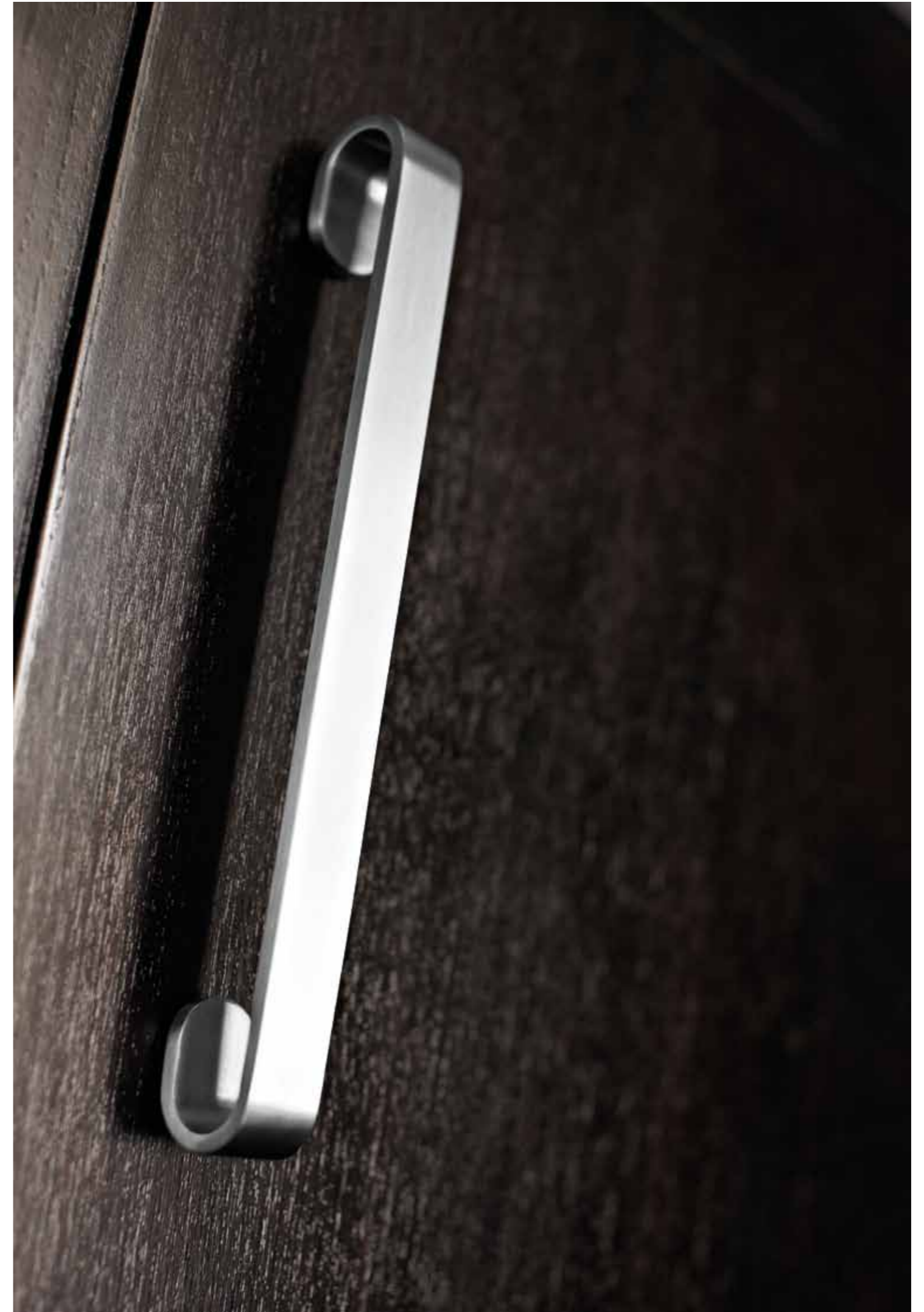





# FOLD by TORD BOONTJE

TB100

massieve deurkruk geveerd op verborgen rozet | solid sprung lever handle on concealed rose

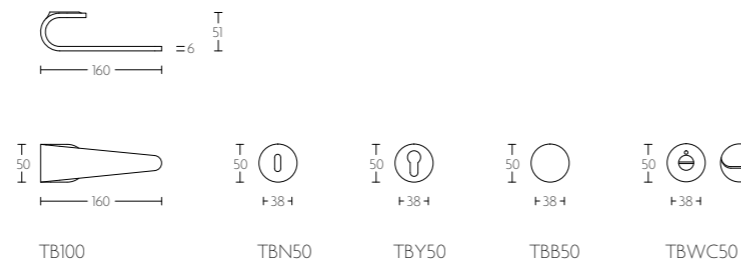

mat roestvast staal  
satin stainless steel

TBN50

sleutelplaatje | key escutcheon

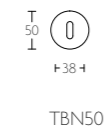

mat roestvast staal  
satin stainless steel

TBY50

cilinderplaatje | profile cylinder escutcheon



mat roestvast staal  
satin stainless steel

TBB50

blind plaatje | blank escutcheon

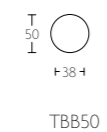

mat roestvast staal  
satin stainless steel

TBWC50

toiletgarnituur | turn and release set

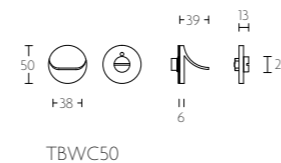

mat roestvast staal  
satin stainless steel

# FOLD by TORD BOONTJE

TBWC50B

toiletgarnituur | turn and release set

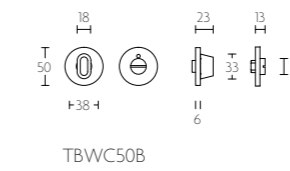

mat roestvast staal  
satin stainless steel

TB110-DK-O

draaikiepgarnituur  
niet afsluitbaar | non-locking tilt and  
turn window handle

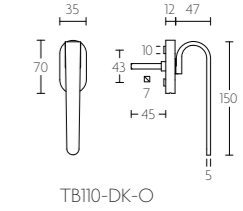

mat roestvast staal  
satin stainless steel

TB110-DKLOCK-O

draaikiepgarnituur  
afsluitbaar | locking tilt and turn  
window handle

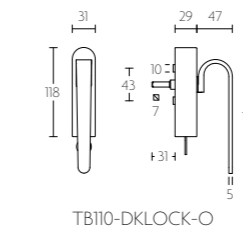

mat roestvast staal  
satin stainless steel

KO-TB110

krukespagnolet inclusief vier  
geleiders, twee eindstukjes  
en twee stangen  
standaard geschikt tot 2900mm | espagnolette bolt with top and  
bottom receiver plate, two rods  
and four rod guides  
standard to suit 2900mm

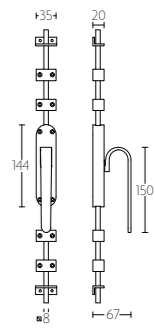

mat roestvast staal  
satin stainless steel

E-LOCK8

slot ten behoeve van  
espagnoletstang 8mm | lock for espagnolette  
rod 8mm

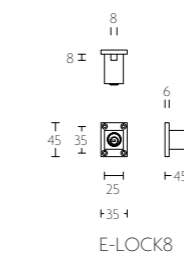

mat roestvast staal  
satin stainless steel

# FOLD by TORD BOONTJE

TB200V | massieve voordeurknop vast op rozet | solid front door knob fixed on rose

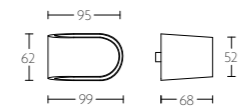

TB200V

mat roestvast staal  
satin stainless steel

TB500 | massieve greep tbv houten, glazen of aluminium deuren doorgaande, niet-doorgaande of paarsgewijze bevestiging | solid pull handle for timber, glass or aluminium doors bolt through, concealed or back to back fixings



TB500

mat roestvast staal  
satin stainless steel

TB20/160 | massieve meubelgreep | solid cabinet handle

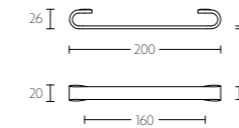

TB20/160

mat roestvast staal  
satin stainless steel

TB20/320 | massieve meubelgreep | solid cabinet handle

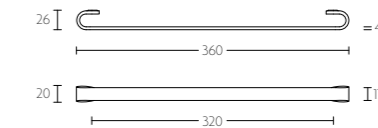

TB20/320

mat roestvast staal  
satin stainless steel

TB501 | massieve greep tbv houten, glazen of aluminium deuren doorgaande, niet-doorgaande of paarsgewijze bevestiging | solid pull handle for timber, glass or aluminium doors bolt through, concealed or back to back fixings



TB501

mat roestvast staal  
satin stainless steel

LBVEIL | massieve veiligheidscilinderrozet | solid security escutcheons

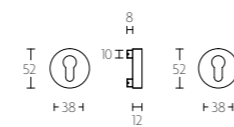

LBVEIL



mat roestvast staal  
satin stainless steel

TB20M | massieve meubelknop | solid cabinet knob

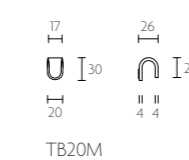

TB20M

mat roestvast staal  
satin stainless steel

TB230 | massieve set hefschuifdeurbeslag inclusief schuifdeurkom voor buitenzijde | single solid internal lift-up sliding door handle with external flush pull

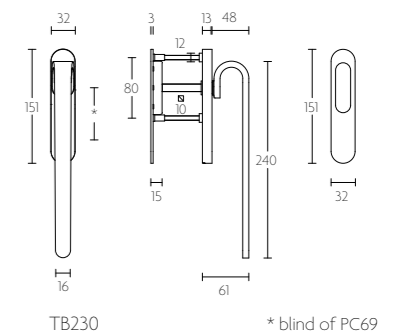

TB230

\* blind of PC69  
\* blind or Y69

mat roestvast staal  
satin stainless steel

LBVEIL-KT | massieve veiligheidscilinderrozet | solid security escutcheons

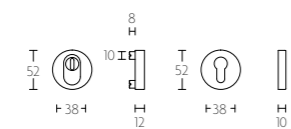

LBVEIL-KT



mat roestvast staal  
satin stainless steel

TB50 | beldrukker met roestvast stalen drukertje | bell push with stainless steel bell button



TB50

mat roestvast staal  
satin stainless steel

TB230PA | massieve paarsgewijze set hefschuifdeurbeslag | pair of solid lift-up sliding door handles

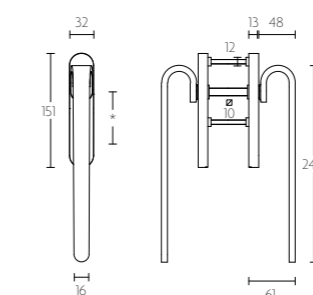

TB230PA

\* blind of PC69  
\* blind or Y69

mat roestvast staal  
satin stainless steel