

FOR PRODUCT SPECIFICATION & DEALER SUPPORT CALL YOUR ACCOUNT MANAGER OR CONTACT US : 1-877-777-0592 www.index-d.com/ghostop

PATENT PENDING  **STRONG MAGNET WARNING!**

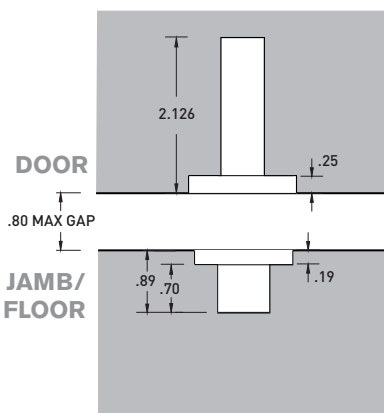

preparation

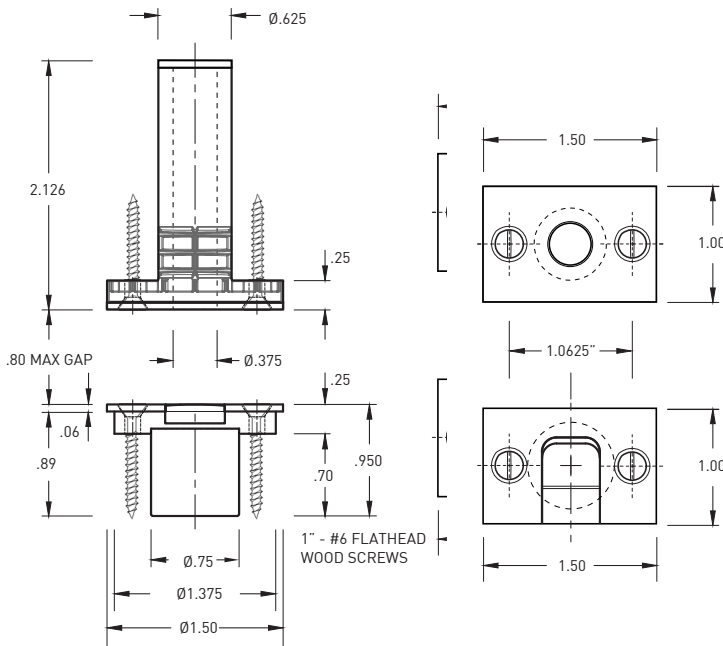
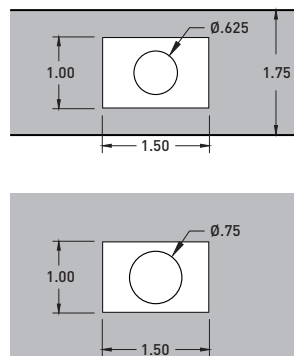

FEATURES:

The Ghostop **GS200** provides a positive stop in side or head jambs for lighter swing and pivot doors, where visual alignment with a straight surface is preferred. The ramp integrated in the strike makes for smooth opening of closets, cabinets, and doors. Note, GS200 does not provide a positive latch, but a minimal magnetic hold.

- maximum door undercut/jamb gap: **.80"**
- spring-loaded **high-density Delrin® pin**
- Delrin® pin assembly and strike
- series 316 marine-grade stainless steel spring
- rectangular strike in stainless steel or brass
- proprietary graduated recess (the Delrin® ramp)
- concealed neodymium magnet
- decorative wood screws finished to match
- maintenance-free

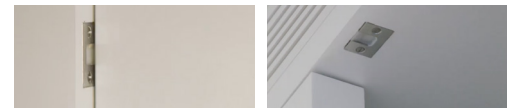

STANDARD FINISHES:

	GS200-SSS-W	satin stainless steel with white Delrin® strike disc
	GS200-ORB-B	US10B oil-rubbed bronze with black Delrin® strike disc
	GS200-PCH-W	polished chrome, plated with white Delrin® strike disc
	GS200-SNL-W	satin nickel, plated with black Delrin® strike disc
	GS200-PNL-W	polished nickel, plated with white Delrin® strike disc
	GS200-PBU-W	polished brass - unlacquered with white Delrin® strike disc
	GS200-SBU-W	satin brass - unlacquered with white Delrin® strike disc
	GS200-BLK-B	matte black with black Delrin® strike disc
	GS200-WHT-W	matte white with white Delrin® strike disc

EXTRA STRIKE SETS, to create positive stops in both open and closed positions, include the rectangular strike coverplate, the Delrin® strike w/ramp and fasteners. These can be ordered using product code: **GS200-SP-XXX-X**

INSTALLATION :

- Install Pin Assembly along bottom of door at desired location.
- Pin Assembly bore must be thoroughly cleaned to ensure proper operation.
- Install rectangular Strike Plate in jamb, or other surface, centered with Pin Assembly.
- Align the strike plate ramp with the pin assembly for your door swing prior to fixing the coverplate screws.