

FOR PRODUCT SPECIFICATION & DEALER SUPPORT CALL YOUR ACCOUNT MANAGER OR CONTACT US : 1-877-777-0592 www.index-d.com/ghostop

PATENT PENDING  **STRONG MAGNET WARNING!**

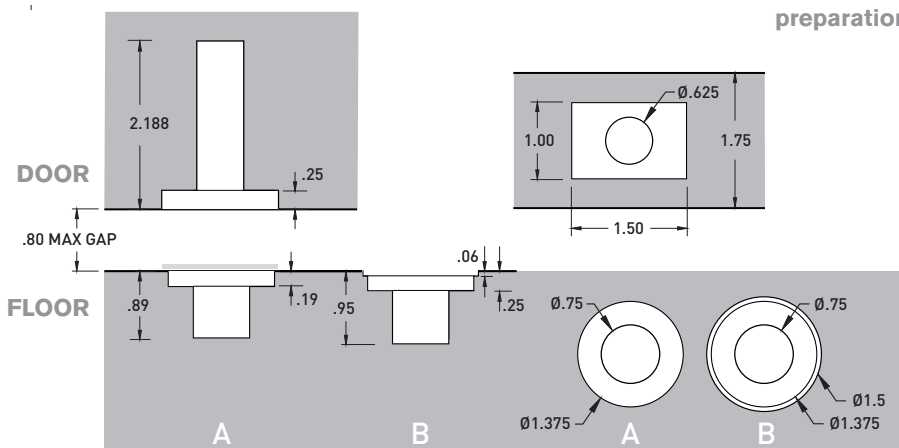
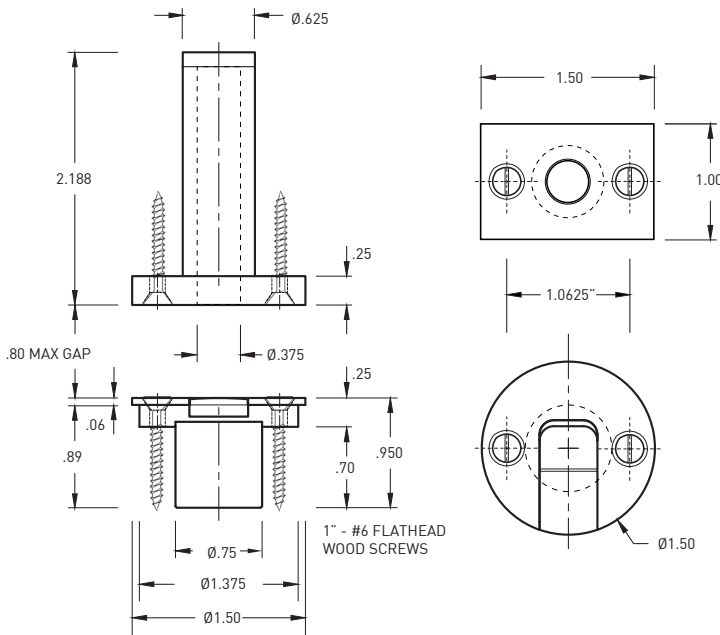

preparation

**FEATURES:**

The Ghostop **GS300XD** was developed to provide a flush-to-the floor door stop for heavier doors on any surface zero clearance required. The GS300XD doorstop features a solid stainless steel pin. Note, GS300XD does not provide a positive latch, but offers a minimal magnetic hold.

- Zero Clearance Solution, no trip hazard
- spring-loaded retracting **stainless steel pin**
- maximum door undercut: **.80"**
- solid milled brass pin assembly
- series 316 marine-grade stainless steel spring
- round strike plate in stainless steel or brass
- proprietary graduated recess (the Delrin® ramp)
- concealed neodymium magnet
- decorative wood screws finished to match
- maintenance-free



**STANDARD FINISHES :**

-  **GS300XD-SSS-W** satin stainless steel with white Delrin® strike disc
-  **GS300XD-ORB-B** US10B oil-rubbed bronze with black Delrin® strike disc
-  **GS300XD-PCH-W** polished chrome, plated with white Delrin® strike disc
-  **GS300XD-SNL-W** satin nickel, plated with black Delrin® strike disc
-  **GS300XD-PNL-W** polished nickel, plated with white Delrin® strike disc
-  **GS300XD-PBU-W** polished brass - unlacquered with white Delrin® strike disc
-  **GS300XD-SBU-W** satin brass - unlacquered with white Delrin® strike disc
-  **GS300XD-BLK-B** matte black with black Delrin® strike disc
-  **GS300XD-WHT-W** matte white with white Delrin® strike disc

**EXTRA STRIKE SETS**, to create positive stops in both open and closed positions, include the circular strike coverplate, the delrin strike w/ramp, magnet, and fasteners. These can be ordered using product code: **GS300-SP-XXX-X**

**INSTALLATION :**

- Install Pin Assembly along bottom of door at desired location.
- Pin Assembly bore must be thoroughly cleaned to ensure proper operation.
- Install round Strike Plate in floor, or ceiling, centered with Pin Assembly.
- Align the strike plate ramp with the pin assembly for your door swing prior to fixing the coverplate screws.